

COMMERCIAL POOL

Natural Pool Water Treatment

PZ2-1 & PZ2-2 - Commercial and Residential Pools & Spas
Ozone Generator Systems

*INSTALLATION GUIDE and
OPERATION MANUAL*



T-O₃ NATURAL TECHNOLOGY

Reduces Chemical Usage,
Improves Sanitation
Produces Crystal Clear Water

Copyright 2007

PZ2-1 & PZ2-2

IMPORTANT SAFETY INSTRUCTIONS

Read and Follow All Safety Instructions

- Read and be familiar with this manual before installing, operating, or performing maintenance on the PZ2.
- Voltage must be determined before unit is installed.
- Replace damaged cord immediately.
- Do not bury cord.
- Connect only to a properly grounded, grounding type receptacle.
- Install at least 5 feet from the inside wall of the pool using non-metallic plumbing. The ozone generator is to be located one foot above the maximum water level to prevent water from contacting electrical equipment. Install to provide drainage of compartment for electrical components.
- A pressure wire connector is provided in the control box inside the unit to permit connection of a minimum No. 8 AWG solid copper bonding conductor between this point and any metal equipment, metal enclosures of electrical equipment, metal water pipe, or conduit within 5 feet of the unit as needed to comply with local requirements.
- Wear safety glasses when drilling and tapping holes for installation of unit.

WARNING: Short term inhalation of high concentrations of ozone and long term inhalation of low concentrations of ozone can cause serious harmful physiological effects. Do not inhale ozone gas produced by this device.



WARNING: Disconnect all power to pool equipment prior to installation, maintenance, or removal of the PZ2.



WARNING: Do not permit children to operate this product



WARNING: To avoid risk of electric shock, fire, or injury, service should only be performed by a qualified pool service professional.



WARNING: Installation must be performed in accordance with the National Electric Code and any applicable local or state installation codes.



WARNING: When mixing acid with water, ALWAYS ADD ACID TO WATER, NEVER WATER TO ACID.

NOTE: The instructions in this document provide general installation guides. Consult your dealer for specific installation instructions. Additional information is available at www.prozoneint.com. Check system for any visible shipping damage. If damage has occurred, contact the delivery company and your dealer immediately. Before beginning installation, please turn to the Installation Kit Inventory Section and verify that all listed parts are on hand.

Tools Needed: Cordless Power Drill, Screw Driver, Adjustable Wrench, Pliers, Wall Mount Screw Anchors, Knife

SAVE THESE INSTRUCTIONS

PZ2-1 & PZ2-2

INTRODUCTION TO OZONE

Ozone (O₃) is generated by irradiating air or oxygen (O₂) with ultraviolet radiation. Ozone is a molecule of oxygen that is formed when three atoms of oxygen are bound together instead of the normal two atoms. The extra oxygen atom makes ozone the most powerful oxidizer and sanitizer readily available.

Since ozone is unstable and quickly decomposes to normal oxygen under normal conditions, it cannot be shipped or stored. Therefore, it must be manufactured on site for immediate use. In normal air it lasts about an hour. In normal pool water it lasts just long enough to purify the water - less than 1 second.

Although ozone is mainly thought of as a sanitizer, it acts primarily as an oxidizer in the pool environment. In a typical pool run on chlorine only, up to 90 percent of the chlorine may be used up in reactions unrelated to disinfection. The byproducts of these reactions are combined chlorines. Combined chlorines are the cause of eye irritation, odor, and the other unpleasant side effects of chlorination. When ozone is used, it oxidizes a large portion of the contaminants (usually referred to as bather load) which result in the formation of combined chlorines. The result is that more chlorine is available for disinfection and less chlorine is required to maintain the pool. Ozone also provides some disinfection, but an ozone residual cannot be established, so the use of chlorine or bromine is always recommended.

PREPARING FOR INSTALLATION

1. Install your PZ2-1 or PZ2-2 Ozonator so that dust, sand, debris, chemicals, or other foreign objects are not sucked into the compressor's intake fan or hose (if equipped with Noise Attenuator).
2. Check electrical system: 240VAC double switched per N.E.C. standards; 120VAC single switched.
3. Check for Suction Line Check Valve. Equipment may draw if no check valve is present.
4. Balance the pH.
5. Backwash the filter.
6. Shock the pool with a non-lithium-based material. The use of Calcium Hypochlorite or Sodium Hypochlorite is recommended.

The Table below summarizes the levels that are recommended by The Association of Pool and Spa Professionals (APSP). It is important to maintain these levels in order to prevent corrosion or scaling and to ensure maximum enjoyment of the pool. Test your water periodically. Take a water sample in to be professionally tested by a Pool and Spa Professional at least once a month. See our web site for more information on Basic Pool Water Chemistry.

pH	7.2 – 7.6
Alkalinity	80 – 120 ppm
TDS	< 1,000
Cyanuric Acid	30 – 70 ppm
Free Chlorine	0.5 – 1.5 ppm
Calcium Hardness	60 – 400 ppm
Metals	0 ppm
Nitrates / Phosphates	< 30 ppm

SADDLE CLAMP ASSEMBLY

For bypass Entrance, (before Ball Valve)
Using 1-1/2" pipe, Assemble:
Venturi Injector (Note direction)
Saddle Clamp Top & Bottom
Top & Bottom Adapters
Bushing (Note direction)
Gasket
Screws (2)
Nuts (2)

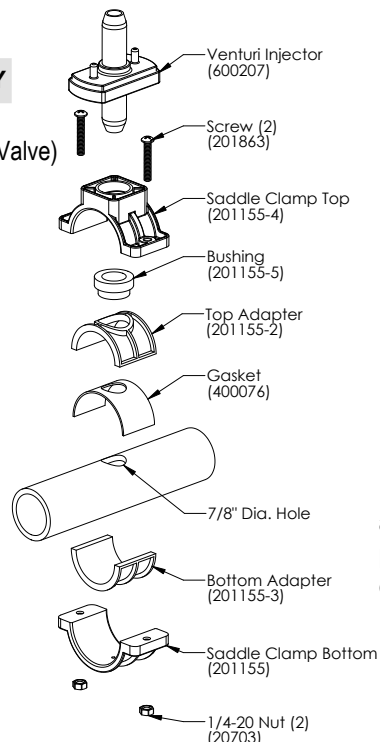

For bypass Exit, (after Ball Valve)
Using 1-1/2" pipe, Assemble:
PVC Pipe
Saddle Clamp Top & Bottom
Top & Bottom Adapters
Bushing (Note direction)
Gasket
Screws (2)
Nuts (2)

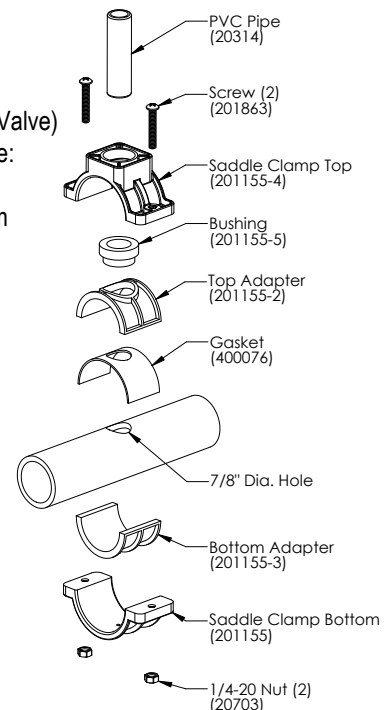

Note: For 2" pipe, do not use 1-1/2" adapters and gasket and turn Bushings so small end points toward Injector (for Entrance) or PVC Pipe (for Exit).

PZ2-1 & PZ2-2

Bypass / Venturi Injection Installation

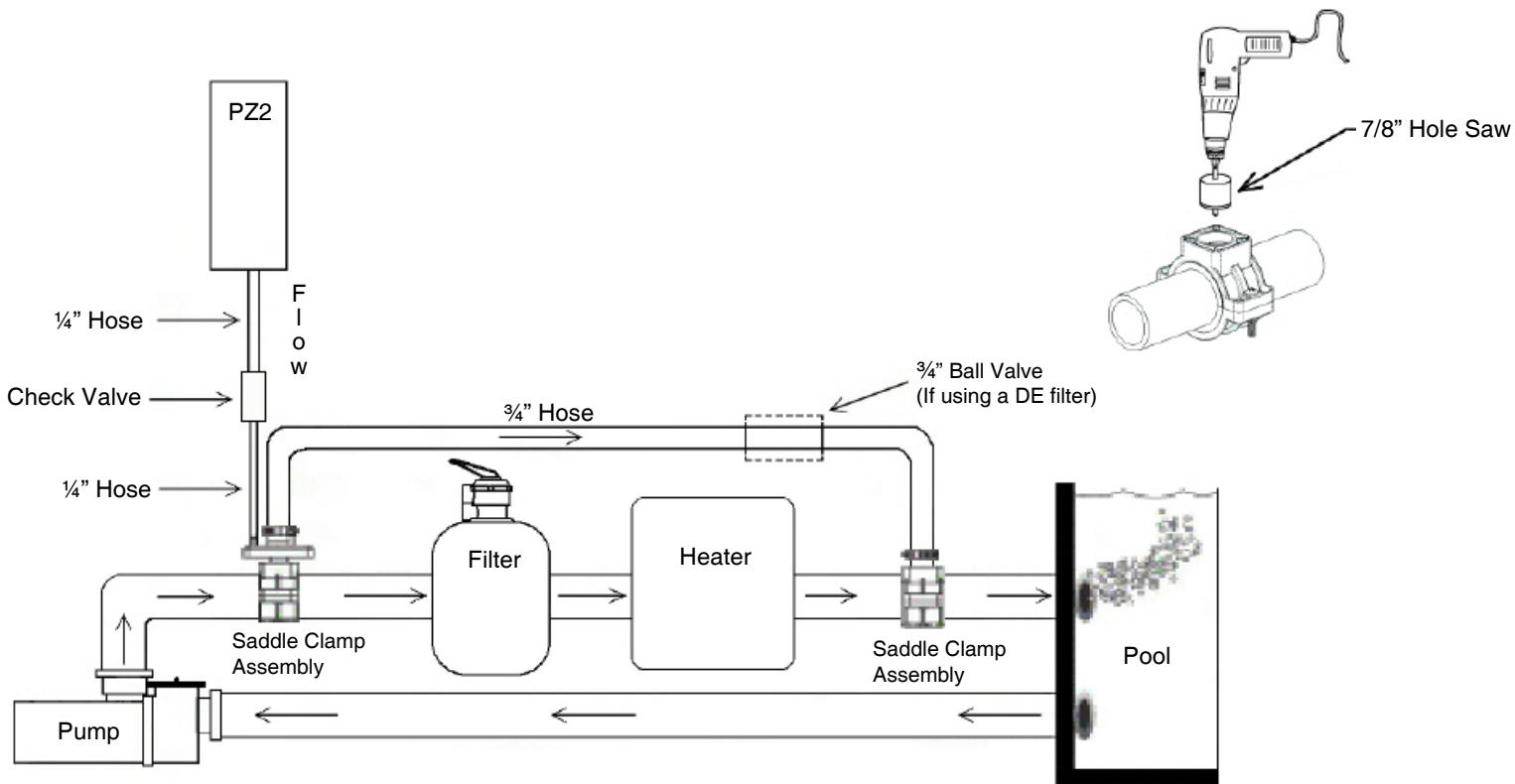

1. Turn pump OFF.
2. Locate section of existing plumbing in which you choose to install the ENTRANCE leg of the bypass. Location should be in any accessible area after the pump, but before the filter.
3. Install Saddle Clamp Top & Bottom, (and adapters if needed), without Bushing, (this will be used as a guide for your installation hole).
4. Drill a 7/8" hole through one wall of the pipe, using power drill, being careful not to drill too deep to avoid penetrating the opposite side of the plumbing.
5. Locate section of existing plumbing in which you choose to install the EXIT leg of the bypass. Location should be in any accessible area after the filter, and heater (if equipped).
6. Repeat steps 3 & 4.
7. Remove both Saddle Clamp Assemblies.
8. Using components listed, mount one Saddle Clamp Assembly on Entrance bypass location with the INLET side of the Venturi Injector mounted in the Saddle Clamp Bushing, (ozone ports should be facing upward).
9. Using components listed, mount the other Saddle Clamp Assembly on Exit bypass location with the 1/2" x 3" PVC pipe mounted in the Saddle Clamp Bushing.
10. Attach one end of 3/4" clear hose to Venturi Injector and secure with a metal clamp. Attach other end of 3/4" clear hose to 1/2" x 3" PVC pipe and secure with a metal clamp.
11. Mount the PZ2 Ozone Generator vertically on wall with compressor at lower end, using two holes in rain shield. Place system at or above water level. If unit must be mounted below water level, loop the hose so that at some point it is above water level (a solenoid control valve may be necessary).
12. Apply Teflon tape to the threads of a 1/2" MPT x 1/4" HB fitting, part number 20230, and screw into the end of the Check Valve that has the spring in it, (This is the INLET side of the Check Valve). Mark this end as "INLET".
13. Apply Teflon tape to the threads of a 1/2" MPT x 1/4" HB fitting, part number 20230, and screw into the opposite of the Check Valve, (This is the OUTLET side of the Check Valve). Mark this end as "OUTLET".
14. Cut a 6 inch length of 1/4" hose and connect one end to the OUTLET side of the Check Valve and connect the other end to the open ozone port (Marked #1) on the Venturi Injector. Secure with 1/2" plastic clamps.
15. Cut a length of 1/4" hose long enough to reach between the Ozone Generator and the Check Valve.
16. Attach one end of the 1/4" hose to the Ozone Generator and connect the other end to the INLET side of the Check Valve. Secure with 1/2" plastic clamps.
17. Slip the M09 Noise Attenuator onto the 1" fitting at the rear of the PZ2 (if equipped) (Installation manual supplied with M09).
18. Electrical Installation: System is either 120 or 240 VAC, 50/60 HZ. Wire Prozone Ozone Generator system to circulation pump switch or timer. Prozone system and circulation pump should be started simultaneously. Use N.E.C. or local code grounding and installation procedures for swimming pool equipment.

Note: If using a Diatomaceous Earth filter, install a 3/4" ball valve in the 3/4" hose to the output side of the venturi, as shown.

CAUTION: Make sure the voltage is the same as prescribed on the side of the Prozone ozone generator. Overvoltage will void customer warranty.

PZ2-1 & PZ2-2

Direct Injection Installation

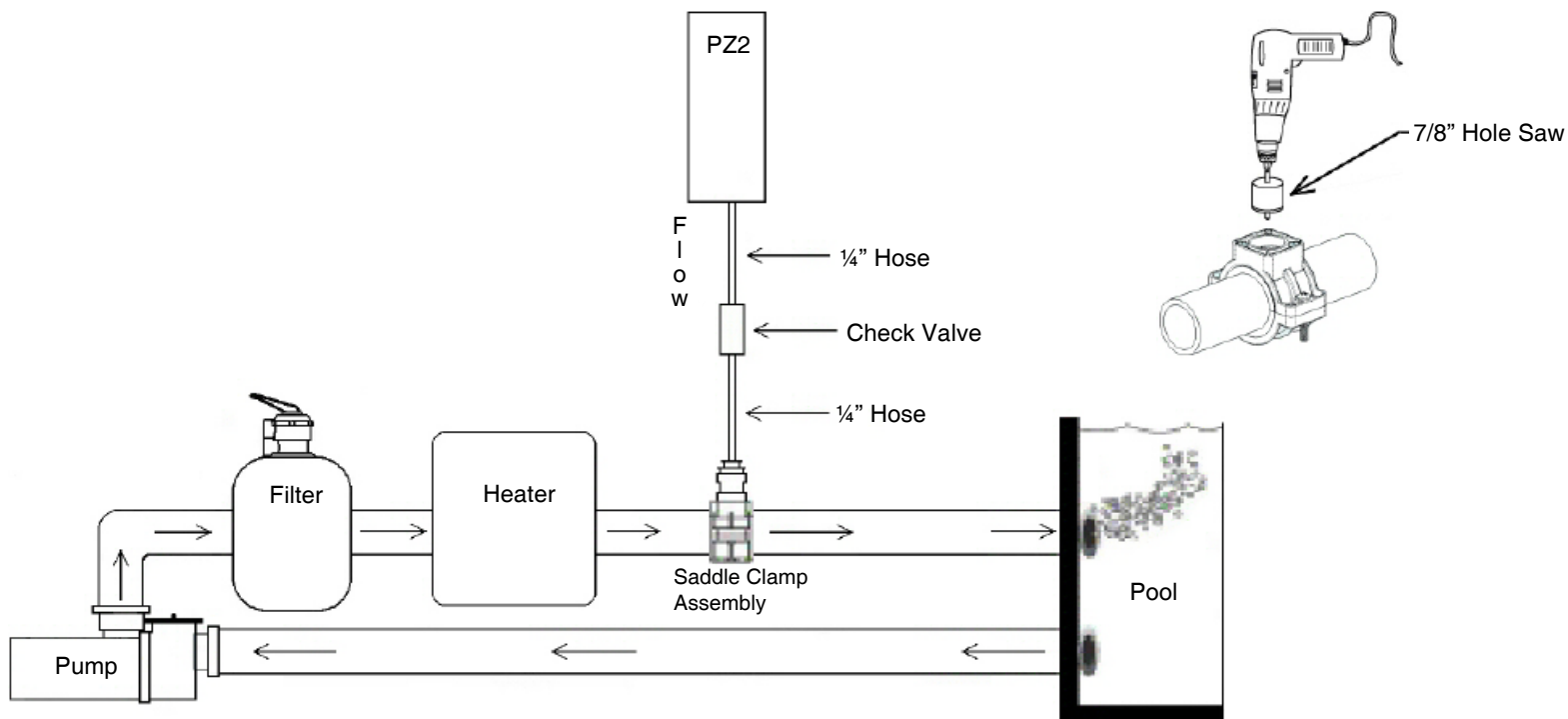

NOTE: There must be at least four feet of return line between the point where the ozone bubbles are injected and the pool. If there is not four feet of return available, a flexible loop can be added to the return line.

1. Turn pump OFF.
2. Locate section of existing plumbing in which you choose to install the Direct Injection Saddle Clamp Assembly. Location should be in any accessible area after the pump, filter, and heater, (if equipped).
3. Install Saddle Clamp Top & Bottom, (and adapters if needed), without Bushing, (this will be used as a guide for your installation hole).
4. Drill a 7/8" hole through one wall of the pipe, using a power drill, being careful not to drill too deep to avoid penetrating the opposite side of the plumbing. Remove the Saddle Clamp Assembly.
5. Apply Teflon tape to male threads of (2) fittings, part numbers 20230 and 20303. Assemble all (3) fittings, 20230, 20303, and 201669, and glue to 3" long PVC pipe, part number 20314. Allow glue to dry for at least 10 minutes.
6. Using components listed, mount the Saddle Clamp Assembly, (Step 5), into the Saddle Clamp Bushing and tighten both screws.
7. Mount the PZ2 ozone generator vertically on wall with compressor at lower end, using two holes in rain shield. Place system at or above water level. If unit must be mounted below water level, loop the hose so that at some point it is above water level (a solenoid control valve may be necessary).
8. Apply Teflon tape to the threads of a 1/2" MPT x 1/4" HB fitting, part number 20230, and screw into the end of the Check Valve that has the spring in it, (This is the INLET side of the Check Valve). Mark this end as "INLET".
9. Apply Teflon tape to the threads of a 1/2" MPT x 1/4" HB fitting, part number 20230, and screw into the opposite of the Check Valve, (This is the OUTLET side of the Check Valve). Mark this end as "OUTLET".
10. Cut a 6 inch length of 1/4" hose and connect one end to the OUTLET side of the Check Valve and connect the other end to ozone fitting on the 3" PVC pipe assembly. Secure with 1/2" plastic clamps.
11. Cut a length of 1/4" hose long enough to reach between the Ozone Generator and the Check Valve.
12. Attach one end of the 1/4" hose to the Ozone Generator and connect the other end to the INLET side of the Check Valve. Secure with 1/2" plastic clamps.
13. Slip the M09 Noise Attenuator onto the 1" fitting at the rear of the PZ2 (if equipped) (Installation manual supplied for M09).
14. Electrical Installation: System is either 120 or 240 VAC, 50/60 HZ. Wire Prozone Ozone Generator system to circulation pump switch or timer. Prozone system and circulation pump should be started simultaneously. Use N.E.C. or local code grounding and installation procedures for swimming pool equipment. .

CAUTION: Make sure the voltage is the same as prescribed on the side of the Prozone ozone generator. Overvoltage will void customer warranty.

PZ2 SERIES OZONE GENERATOR OPERATION

The Prozone system works when air is drawn across a high-energy vacuum ultraviolet (VUV) lamp, converting some air to ozone. The ozone is introduced into the water either by direct injection or through a bypass venturi system. For direct injection, the venturi injector is inserted directly into the return line of the pool creating a suction (vacuum) that draws the ozone into the venturi as the water returns to the pool. The bypass venturi system takes water directly after the circulation pump (highest pressure point), bypasses part of the water flow past filters, heater, etc. through a venturi injector, through contact tubing and then returns the water back to the pool return line. A check valve is employed to prevent water backup in the event of system failure. The system should be run 6-8 hours per day for best effect. Run time may vary depending on usage.

PZ2-1 & PZ2-2

INSTALLATION KIT INVENTORY

P20 Installation Kit PZ2-1 & PZ2-2 Series with Bypass / Venturi Injector

Description	Part Number	Quantity
784 Venturi Injector	600207	1
Plastic Clamp 1/2"	20185	4
Metal Clamp 1 1/4"	20067	4
Polybraid Hose 1/4"	20260	72"
Clear Hose 3/4"	20264	96"
PVC Pipe 1/2" x 3"	20314	1
Fitting 1/2" MPT x 1/4" HB	20230	2
Check Valve 1/2"	20215	1
Saddle Clamp, Outer Top	201155-4	2
Saddle Clamp, Outer Bottom	201155	2
Saddle Clamp, Inner Top	201155-2	2
Saddle Clamp, Inner Bottom	201155-3	2
Saddle Clamp Gasket	400076	2
Saddle Clamp Bushing	201155-5	2
Screw #14 x 1-1/2" PPMS	201863	4
Nut 1/4-20	20703	4

D03 Installation Kit PZ2-1 & PZ2-2 Series with Direct Injection

Description	Part Number	Quantity
Plastic Clamp 1/2"	20185	4
Polybraid Hose 1/4"	20260	120"
Fitting 1/2" MPT x 1/4" HB	20230	3
PVC Fitting 3/4" MPT x 1/2" FPT	20303	1
PVC Fitting 3/4" FPT x 1/2" SL	201669	1
PVC Pipe 1/2" x 3"	20314	1
Check Valve 1/2"	20215	1
Saddle Clamp, Outer Top	201155-4	1
Saddle Clamp, Outer Bottom	201155	1
Saddle Clamp, Inner Top	201155-2	1
Saddle Clamp, Inner Bottom	201155-3	1
Saddle Clamp Gasket	400076	1
Saddle Clamp Bushing	201155-5	1
Screw #14 x 1-1/2" PPMS	201863	2
Nut 1/4-20	20703	2

Note: For pools with Diatomaceous Earth filter and Bypass / Venturi Injector installation, add (1) 3/4" Ball Valve, (2) 3/4" MPT x HB fittings, and (2) 1 1/4" metal clamps.

TROUBLESHOOTING GUIDE

PROBLEM	PROBABLE CAUSE	REMEDY
No light from Prozone unit	Loose wiring	Check all wiring connections
	No power to unit	Check voltage compatibility Check power source
	Defective lamp or other internal component	Return unit to dealer
No bubbles from injector or no evidence of ozone in pool	Excessive back pressure	Check for kinks or clogs in hose or plumbing
	Leak in fitting	Replace fitting
	Filter not working	Check filter
Water in Ozone Generator	Check Valve failure	Verify Check Valve in Venturi is operating properly
Cloudy water; foamy water; scum	Water chemistry out of balance	Check readings and balance accordingly
	Total Dissolved Solids (TDS) level too high	Refer to dealer for proper water testing
	Filter not working	Clean or replace filter

NOTE: Cloudy water may occur when the ozone generator is started. Filter and backwash as necessary.